

1. Description

BLS60R150F, the silicon N-channel Enhanced MOSFETs, is obtained by advanced Super Junction technology which reduce the conduction loss, improve switching performance.

KEY CHARACTERISTICS

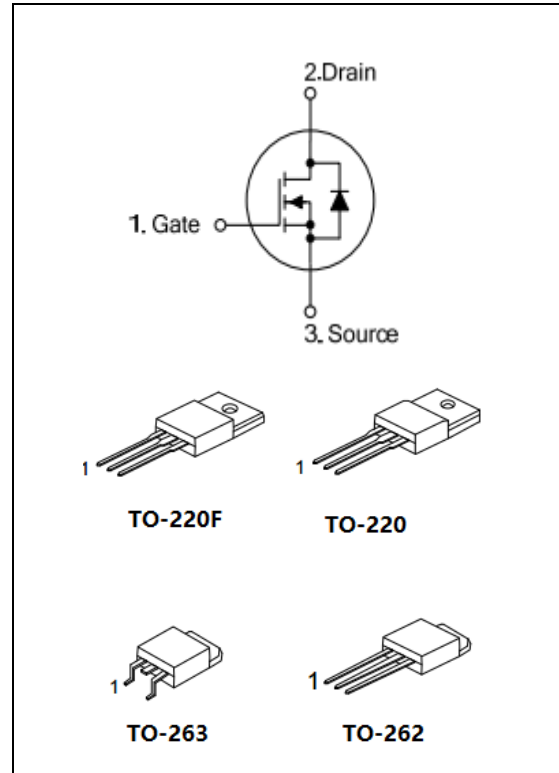
Parameter	Value	Unit
$V_{DS@Tj,max}$	650	V
I_D	23	A
$R_{DS(ON).Typ}$	0.13	Ω

FEATURES

- Fast body diode MOSFET
- Fast Switching
- 100% avalanche tested
- Improved dv/dt capability
- RoHS product

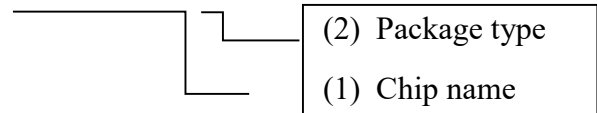
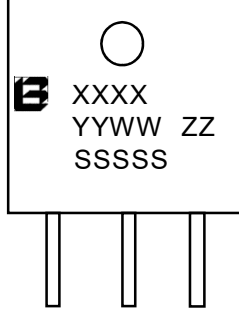
APPLICATIONS

- High frequency switching mode power supply
- Applications using the following topologies:
 LLC / Phase shifted bridge (ZVS) /3-level inverter



ORDERING INFORMATION

Ordering Codes	Package	Product Code	Packing
BLS60R150F-P	TO-220	S60R150F	Tube
BLS60R150F-A	TO-220F		Tube
BLS60R150F-I	TO-262		Tube
BLS60R150F-B	TO-263		Tape Reel
BLS60R150F-W	TO-3PN		Tube

<p>BLS60R150F-A</p>  <p>(1) BLS60R150F:600V 150mΩ (2) A:TO-220F P:TO-220 W:TO-3PN I: TO-262 B: TO-263</p>	 <p>XXXX: Product Code YYWW: Year&Week ZZ: Assembly Code SSSSS: Lot Code</p>
---	---

2. ABSOLUTE RATINGS

 at $T_C = 25^\circ\text{C}$, unless otherwise specified

Symbol	Parameter	Rating	Units
V_{DSS}	Drain-to-Source Voltage	600	V
I_D	Continuous Drain Current	23	A
	Continuous Drain Current $T_C = 100^\circ\text{C}$	14	A
I_{DM}	Pulsed Drain Current(Note1)	69	A
V_{GS}	Gate-to-Source Voltage	± 30	V
E_{AS}	Single Pulse Avalanche Energy(Note2)	600	mJ
dv/dt	Peak Diode Recovery dv/dt (Note3)	15	V/ns
P_D	Power Dissipation TO-220 TO-262 TO-263 TO-3PN	220	W
	Derating Factor above 25°C	1.75	W/ $^\circ\text{C}$
P_D	Power Dissipation TO-220F	42	W
	Derating Factor above 25°C	0.33	W/ $^\circ\text{C}$
T_J, T_{stg}	Operating Junction and Storage Temperature Range	150, -55 to 150	$^\circ\text{C}$
T_L	Maximum Temperature for Soldering	300	$^\circ\text{C}$

3. Thermal characteristics

Thermal characteristics TO-263\TO-262\TO-220\TO-3PN

Symbol	Parameter	RATINGS	Units
$R_{\theta JC}$	Junction-to-Case	0.57	$^\circ\text{C}/\text{W}$
$R_{\theta JA}$	Junction-to-Ambient	62.5	$^\circ\text{C}/\text{W}$

Thermal characteristics TO-220F

Symbol	Parameter	RATINGS	Units
$R_{\theta JC}$	Junction-to-Case	3	$^\circ\text{C}/\text{W}$
$R_{\theta JA}$	Junction-to-Ambient	62.5	$^\circ\text{C}/\text{W}$

4. Electrical Characteristics

 at $T_c = 25^\circ\text{C}$, unless otherwise specified

OFF Characteristics						
Symbol	Parameter	Test Conditions	Values			Units
			Min.	Typ.	Max.	
V_{DSS}	Drain to Source Breakdown Voltage	$V_{GS}=0V$, $I_D=250\mu A$	600	--	--	V
$\frac{\Delta BV_{DSS}}{\Delta T_J}$	Bvdss Temperature Coefficient	$I_D=250\mu A$, Reference 25°C	--	0.63	--	$V/^\circ\text{C}$
I_{DSS}	Drain to Source Leakage Current	$V_{DS}=600V$, $V_{GS}=0V$, $T_J=25^\circ\text{C}$	--	--	10	μA
		$V_{DS}=480V$, $V_{GS}=0V$, $T_J=125^\circ\text{C}$	--	--	500	μA
$I_{GSS(F)}$	Gate to Source Forward Leakage	$V_{GS}=+30V$	--	--	100	nA
$I_{GSS(R)}$	Gate to Source Reverse Leakage	$V_{GS}=-30V$	--	--	-100	nA

ON Characteristics						
Symbol	Parameter	Test Conditions	Values			Units
			Min.	Typ.	Max.	
$R_{DS(ON)}$	Drain-to-Source On-Resistance	$V_{GS}=10V$, $I_D=9A(\text{Note4})$	--	0.13	0.15	Ω
$V_{GS(TH)}$	Gate Threshold Voltage	$V_{DS}=V_{GS}$, $I_D=250\mu A(\text{Note4})$	3	--	5	V

Dynamic Characteristics						
Symbol	Parameter	Test Conditions	Values			Units
			Min.	Typ.	Max.	
R_g	Gate resistance	$f=1.0\text{MHz}$	--	3.2	--	Ω
C_{iss}	Input Capacitance	$V_{GS}=0V$ $V_{DS}=25V$ $f=1.0\text{MHz}$	--	1810	--	PF
C_{oss}	Output Capacitance		--	103	--	
C_{rss}	Reverse Transfer Capacitance		--	52	--	

Switching Characteristics						
Symbol	Parameter	Test Conditions	Values			Units
			Min.	Typ.	Max.	
$t_{d(ON)}$	Turn-on Delay Time	ID = 11A VDD = 400V VGS = 10V RG = 2Ω	--	35	--	ns
t_r	Rise Time		--	29	--	
$t_{d(OFF)}$	Turn-Off Delay Time		--	45	--	
t_f	Fall Time		--	39	--	
Q_g	Total Gate Charge	ID = 11A VDD = 400V VGS = 10V	--	45	--	nC
Q_{gs}	Gate to Source Charge		--	12	--	
Q_{gd}	Gate to Drain ("Miller") Charge		--	17	--	

Source-Drain Diode Characteristics						
Symbol	Parameter	Test Conditions	Values			Units
			Min.	Typ.	Max.	
I_S	Continuous Source Current (Body Diode)	TC=25 °C	--	--	23	A
I_{SM}	Maximum Pulsed Current (Body Diode)		--	--	69	A
V_{SD}	Diode Forward Voltage	IS=11A, VGS=0V(Note4)	--	--	1.2	V
T_{rr}	Reverse Recovery Time	IS=11A, Tj = 25°C dIF/dt=100A/us, VGS=0V	--	189	--	ns
Q_{rr}	Reverse Recovery Charge		--	1039	--	nC
I_{rrm}	Reverse Recovery Current		--	11	--	A

Note1: Pulse width limited by maximum junction temperature

Note2: L=20mH, VD_s=50V, Start T_J=25°C

Note3: ISD = 11A, di/dt ≤ 100A/us, VDD ≤ BVDS, Start T_J=25°C

Note4: Pulse width tp ≤ 300μs, δ ≤ 2%

5. Characteristics Curves

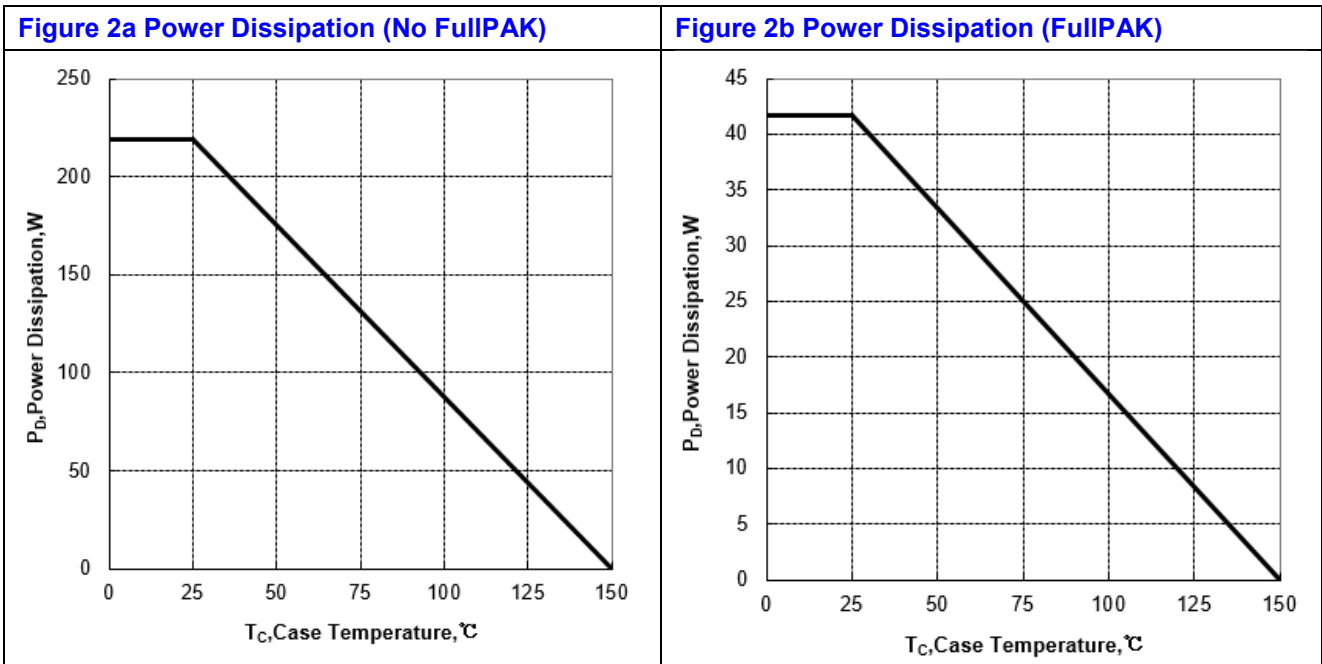
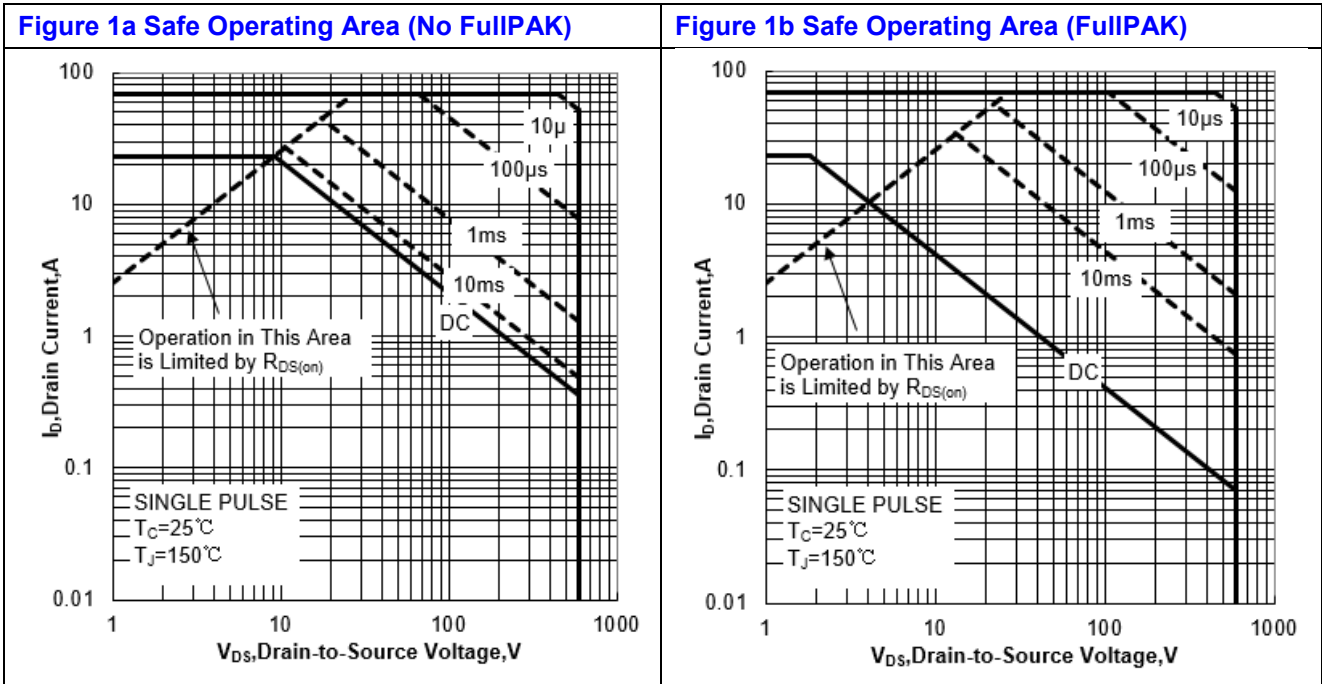


Figure 3a Max Thermal Impedance (No FullPAK)

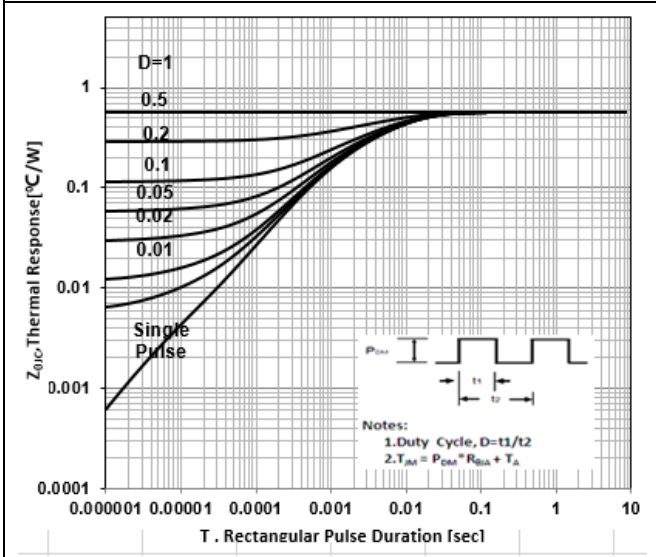


Figure 3b Max Thermal Impedance (FullPAK)

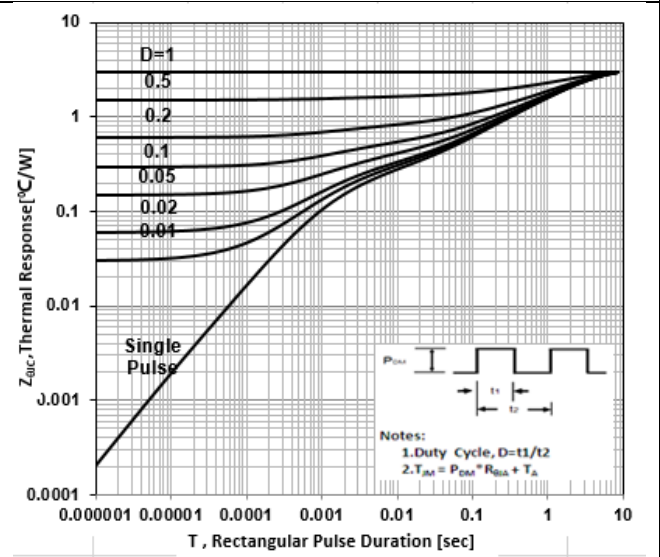


Figure 4 Typical Output Characteristics

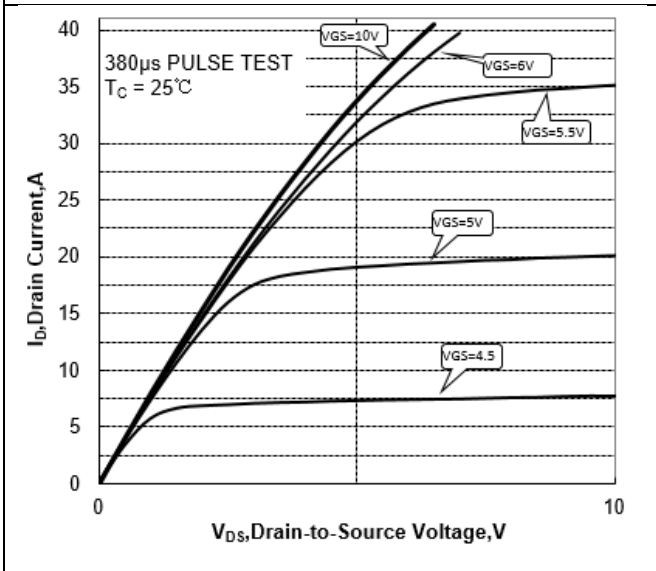


Figure 5 Typical Transfer Characteristics

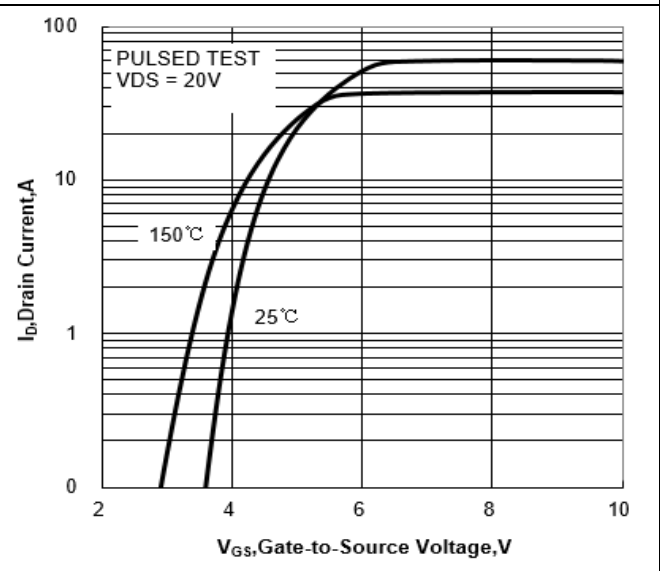


Figure 6 Typical Drain to Source ON Resistance vs Drain Current

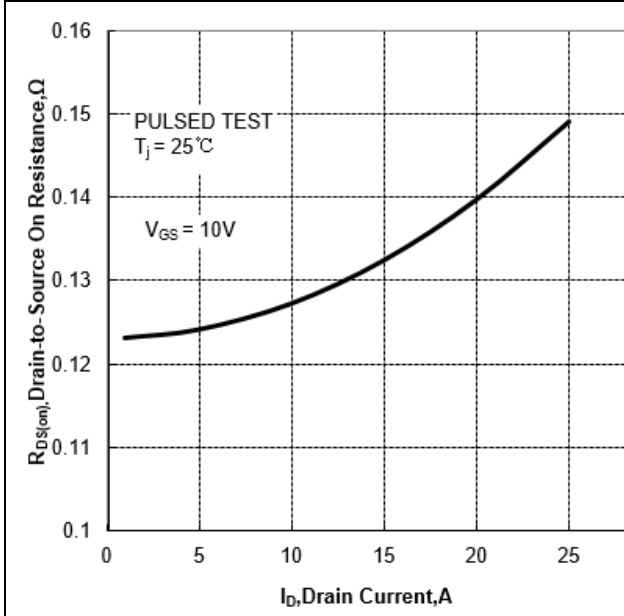


Figure 7 Typical Drain to Source on Resistance vs Junction Temperature

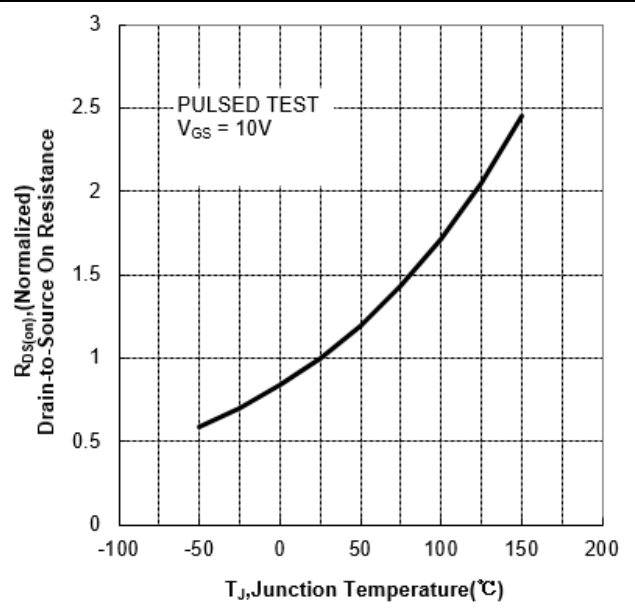


Figure 8 Typical Theshold Voltage vs Junction Temperature

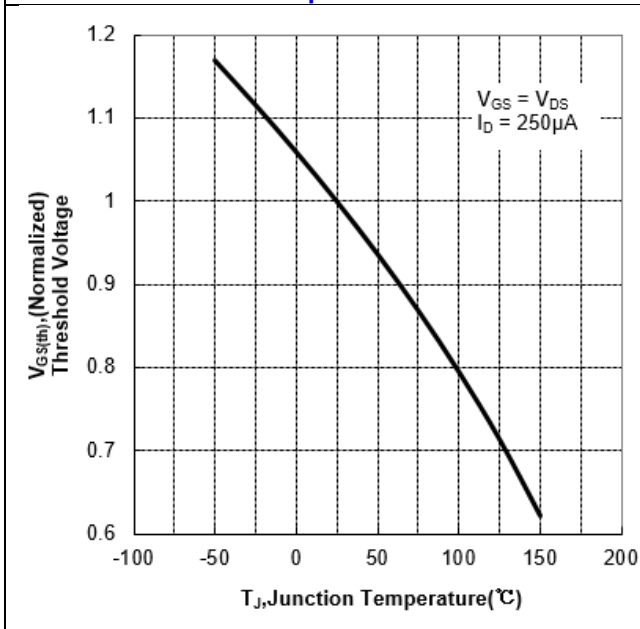


Figure 9 Typical Breakdown Voltage vs Junction Temperature

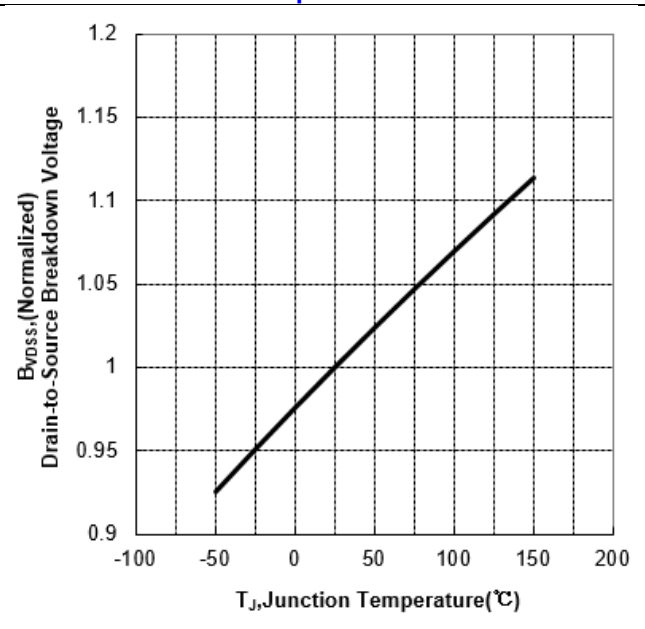


Figure 10 Typical Capacitance vs Drain to Source Voltage

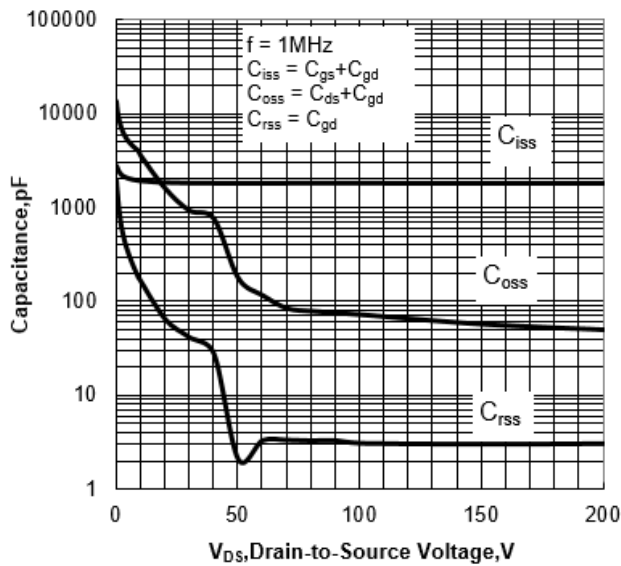
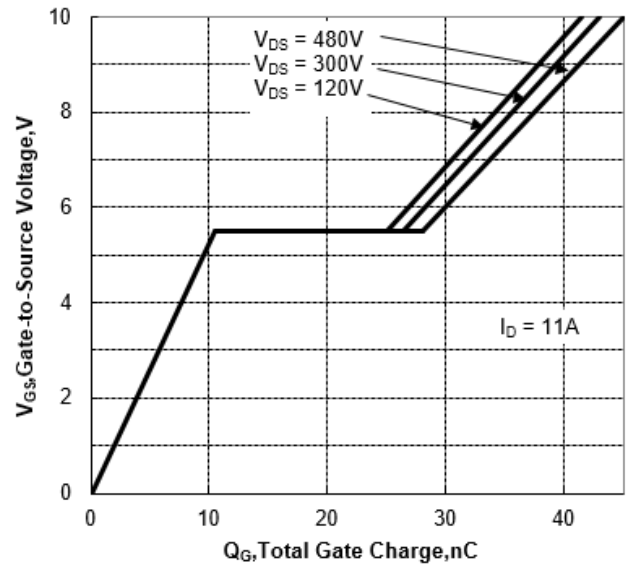


Figure 11 Typical Gate Charge vs Gate to Source Voltage



6. Test Circuit and Waveform

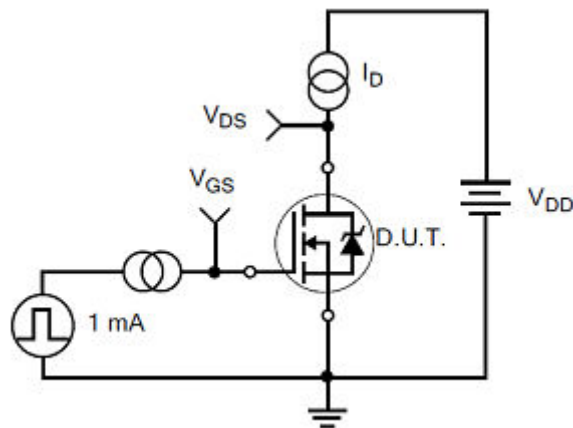
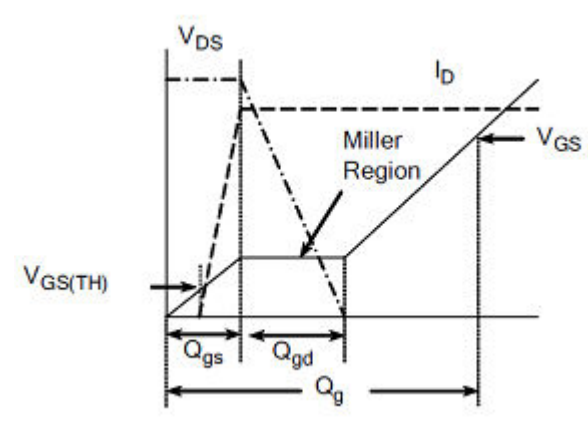
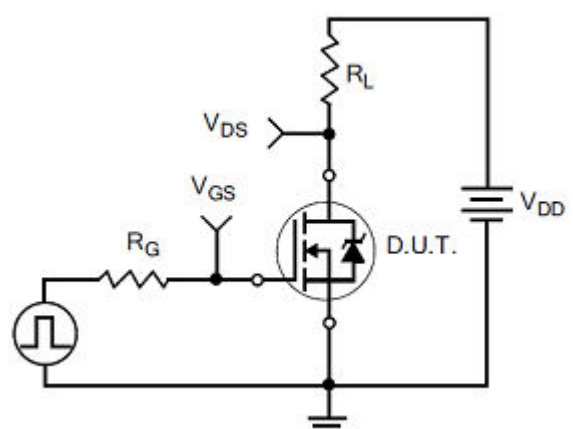
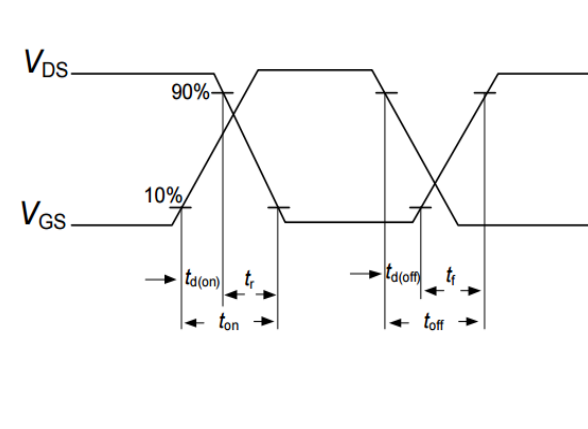
<p>Figure 12 Gate Charge Test Circuit</p> 	<p>Figure 13 Gate Charge Waveforms</p> 
<p>Figure 14 Resistive Switching Test Circuit</p> 	<p>Figure 15 Resistive Switching Waveforms</p> 

Figure 16 Diode Reverse Recovery Test Circuit

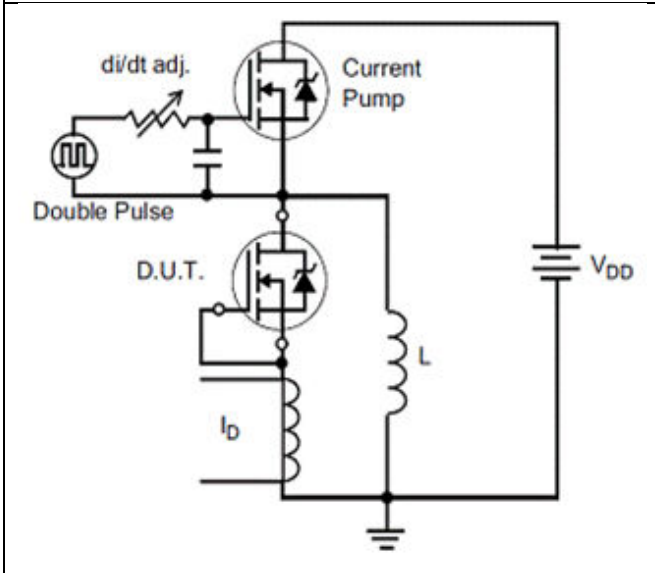


Figure 17 Diode Reverse Recovery Waveform

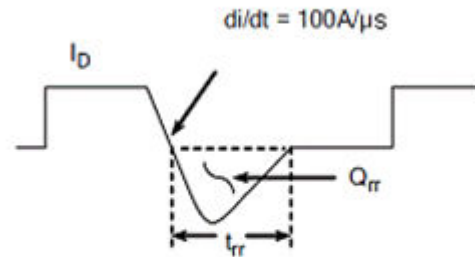


Figure 18 Unclamped Inductive Switching Test Circuit

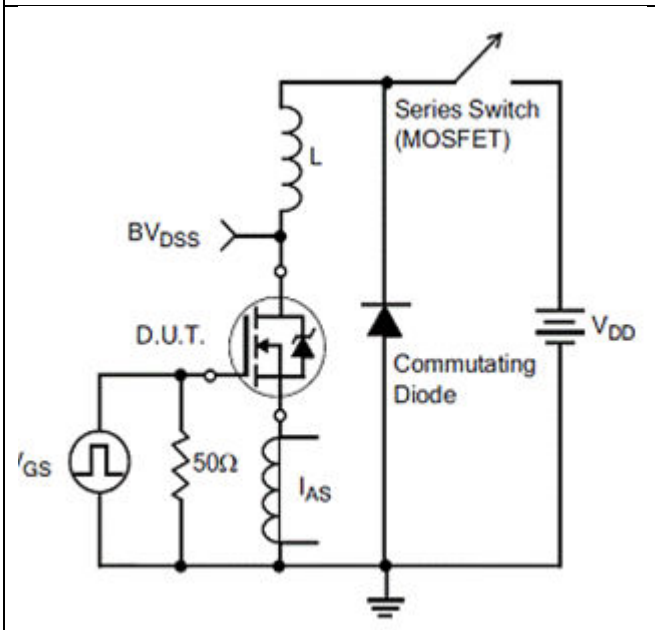
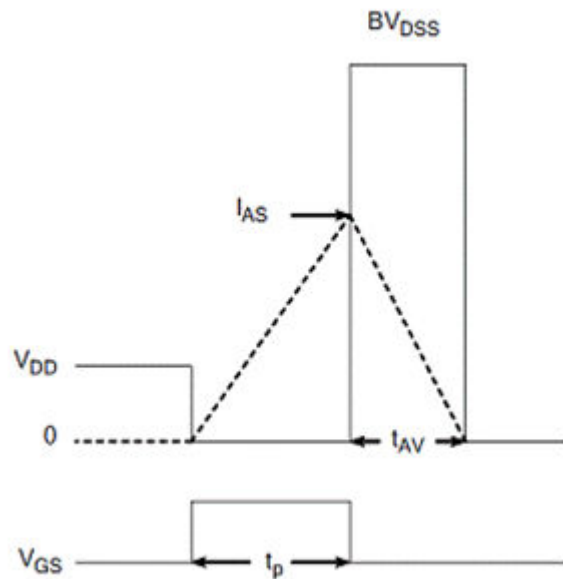
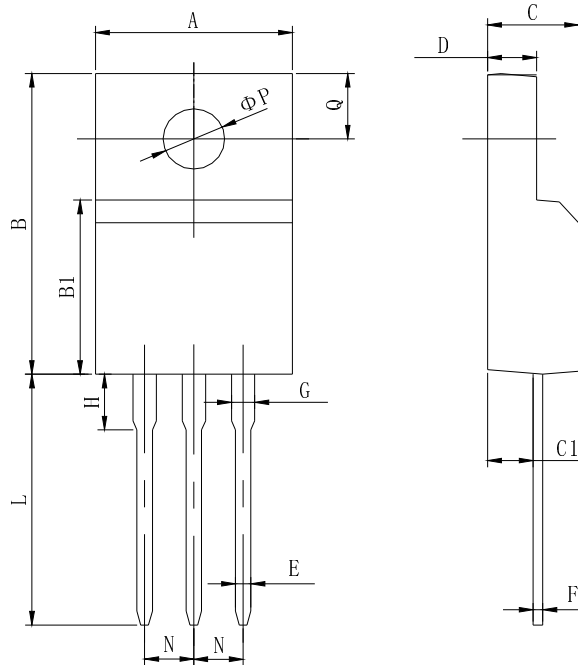


Figure 19 Unclamped Inductive Switching Waveform

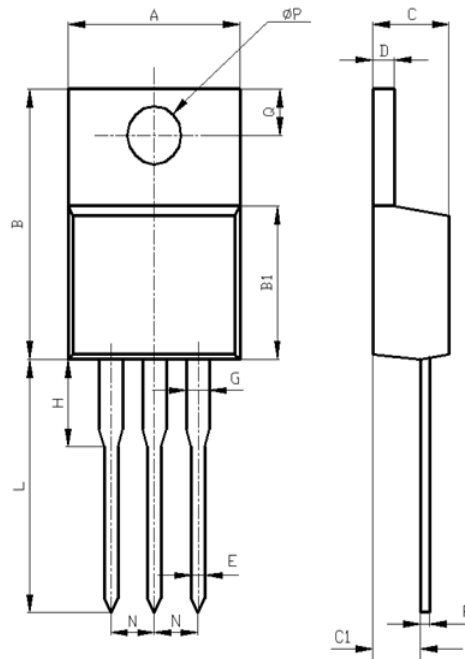


7. Package Description



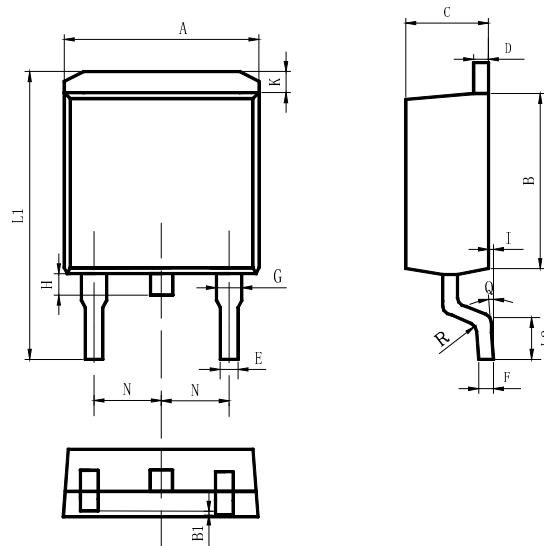
Items	Values(mm)	
	MIN	MAX
A	9.60	10.4
B	15.4	16.2
B1	8.90	9.50
C	4.30	4.90
C1	2.10	3.00
D	2.40	3.00
E	0.60	1.00
F	0.30	0.60
G	1.12	1.42
H	3.40	3.80
	1.60	2.90
L	12.0	14.0
N	2.34	2.74
Q	3.15	3.55
ϕP	2.90	3.30

TO-220F Package



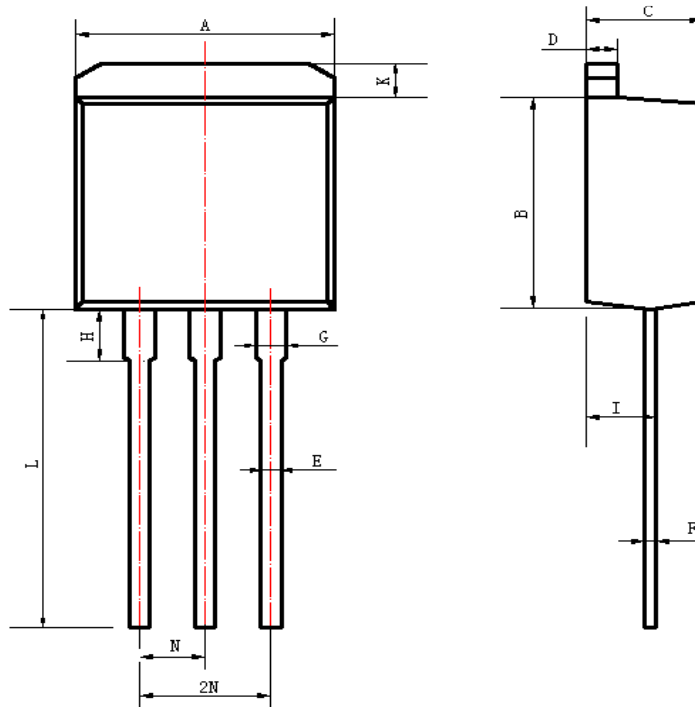
Items	Values(mm)	
	MIN	MAX
A	9.60	10.6
B	15.0	16.0
B1	8.90	9.50
C	4.30	4.80
C1	2.30	3.10
D	1.20	1.40
E	0.70	0.90
F	0.30	0.60
G	1.17	1.37
H	2.70	3.80
L	12.6	14.8
N	2.34	2.74
Q	2.40	3.00
Φ P	3.50	3.90

TO-220 Package



Items	Values(mm)	
	MIN	MAX
A	9.80	10.40
B	8.90	9.50
B1	0	0.10
C	4.40	4.80
D	1.16	1.37
E	0.70	0.95
F	0.30	0.60
G	1.07	1.47
H	1.30	1.80
K	0.95	1.37
L1	14.50	16.50
L2	1.60	2.30
I	0	0.2
Q	0°	8°
R	0.4	
N	2.39	2.69

TO-263 Package



Items	Values(mm)	
	MIN	MAX
A	9.80	10.40
B	8.90	9.50
C	4.30	4.80
D	1.15	1.40
E	0.70	0.91
F	0.28	0.55
G	1.07	1.47
H	3.37	3.77
I	2.50	2.90
K	0.90	1.40
L	12.7	14.7
N	2.35	2.70

TO-262 Package

NOTE:

1. Exceeding the maximum ratings of the device in performance may cause damage to the device, even the permanent failure, which may affect the dependability of the machine. Please do not exceed the absolute maximum ratings of the device when circuit designing.
2. When installing the heat sink, please pay attention to the torsional moment and the smoothness of the heat sink.
3. MOSFETs is the device which is sensitive to the static electricity, it is necessary to protect the device from being damaged by the static electricity when using it.
4. Shanghai Belling reserves the right to make changes in this specification sheet and is subject to change without prior notice.

CONTACT:

上海贝岭股份有限公司（总部）

地址：上海市宜山路 810 号

邮编：200233

电话：021-24261000

产品业务咨询及技术支持

电话：021-24261326

传真 2：021-64852222

邮箱 2：marketing@belling.com.cn

上海贝岭深圳分公司（华南区）

地址：深圳市福田区中心区民田路新华保险大厦 1510 室

邮编：518031

电话：0755-33336776 0755-33336770

传真：0755-33336788

上海贝岭北京办事处（华北区）

地址：北京市西城区新华里 16 号院锦官苑小区 10 号楼 1 单元 1505 室

邮编：100044

电话：010-64179374

传真：010-8835 9236